

Injection Molding

System Recommendations

- L-743 Injection Molding Machine Laser



The L-743 Ultra-Precision Triple Scan® Laser is the ideal instrument to quickly and accurately calibrate the geometry of almost any kind of injection molding machine. It is one of only two lasers in the world to offer three automatically rotating laser planes that are accurate enough for today's ever-tightening tolerances. This creates a powerful tool that not only *finds*, but also *fixes* geometry problems, all in a fraction of the time needed with conventional methods.

The critical alignments of any injection-molding machine are platen-to-platen parallelism and tie-bar squareness. Poor alignment results in premature wear on the mold, part flashing, and stress on tie bars, which can cause breakage. With long lead times and mold costs as much as \$250,000 or more, proper alignment becomes critical.

Platen-to-Platen Parallelism Made Simple with Rotating Laser Planes

Simple to use and easy to set up, the L-743 is an ideal instrument to measure platen-to-platen parallelism. A simple setup procedure positions the laser plane parallel to the fixed platen. Targets are then

repositioned to the movable platen and parallelism is easily measured. With Hamar Laser's Plane 5 Software, setup and parallelism measurements are achieved even faster. And once the laser has been set up, any errors found can be fixed immediately without having to change the setup.

Complete Tie-Bar Squareness Measurements in 2 Setups

With the L-743's built-in squareness, (each laser plane is square to each other) measuring the perpendicularity of the tie bars to the platens is a simple task. In fact, with just two setups you can measure all four tie-bars for squareness in two axes. And since the data is live, squareness errors can be fixed without changing the setup. Given that the laser has a range of 100 feet (30.5 meters) in radius, even the entire length of the largest injection molding machines can easily be measured for squareness.

Significantly Reduce Downtime when Changing Molds

Changing a mold is time consuming and realignment is a necessity. If a mold is slightly out of parallel to the platen, costly flashing and premature wear can occur. Inadequate alignment also results in excess wear on the injection-molding machine itself and can even lead to tie-bar breakage. With each tie bar costing at least \$10,000, proper alignment becomes a big cost saver. The L-743 not only speeds the alignment process significantly, but also reduces tooling and maintenance costs.

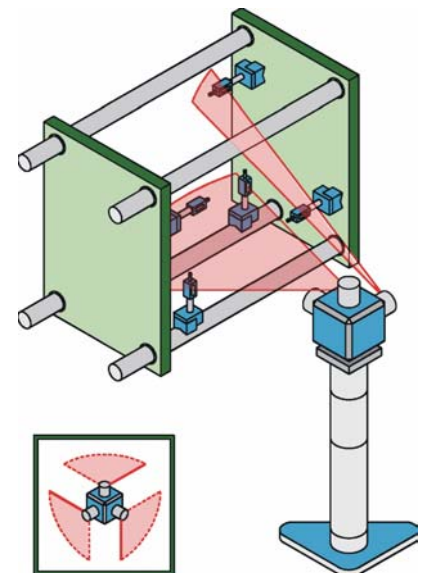

Aligning an Injection Molding Machine



Continuously Sweeping Lasers and Live Data Reduces Downtime

Continuously sweeping lasers and live data output create a powerful combination to align injection molding machines up to 70% faster than traditional methods. Downed machines will be up and running, producing quality parts in record time. HLI's continuously sweeping lasers are far superior to other point-and-shoot laser systems that require time-consuming manual laser rotation and target setup for each point measured. They also allow the use of multiple targets, which is especially helpful for large machine tools.

By providing live alignment data, misalignment errors can be quickly and easily fixed without having to change the setup. The targets come with 70-point magnetic bases for maximum stability, so you can leave them on adjustment points (even horizontally!) when bringing the machine back into alignment. This is a tremendous benefit, especially if you use multiple targets, as you can literally watch the entire platen come back into alignment.

L-743 Significantly Reduces Stack-Up Errors

One of the biggest problems with aligning machine tools using conventional methods is that many different alignment tools must be used, requiring a lot of time and increasing stack-up errors. Another problem is that an alignment is only as good as the tools used to perform it. The machinist level is a good example: it has a resolution of .0005" per foot, which is not very accurate for today's ever-tightening tolerances.

The L-743 laser planes, by contrast, are flat to ½ an arc second (0.00003"/ft or 0.0025mm/M) in a 180° sweep and ¼ arc second (0.000015"/ft or 0.001 mm/M) in a 90° sweep. The laser planes are square to each other to within 1 arc second (0.00006"/ft or 0.005 mm/M). They further have the advantage of creating a single reference from which to measure machine geometry, significantly reducing stack-up errors.

Wireless Targets and Readout Speeds Setup

With Hamar's new line of wireless targets (A-1519, A-1519HR and A-1520), there is no need to string long extension cords to reference targets. The targets have up to a 1" measuring range, a resolution as low as 0.00002" (0.0005 mm) and can be used up to 100 feet (30.5 meters) from the readout. The new R-1309 readout uses a Cassiopeia PDA, color software and a wireless receiver to display up to 4 targets simultaneously. Other features like electronic zeroing and target averaging help to speed setup and alignment.

Software Quickly Collects and Analyzes Data

Hamar's new line of alignment software, combined with newly designed computer interfaces, makes collecting and analyzing machining center alignment data faster and easier. All of the software is Windows based and provides large color graphics. Alignment reports clearly and concisely show the machine's condition. In today's world of stringent ISO 9000 documentation requirements, our software will help you submit alignment reports in record time.

Alignment System Features

- Three automatically rotating laser planes.
- Laser plane flat to 1/2 an arc second (0.00003"/ft or 0.0025mm/M) in a 180° sweep and 1/4 arc second (0.000015"/ft or 0.001 mm/M) in 90° sweep.
- Planes/beams are mutually square to 1 arc second
- Standard Targets: A-1519HR Single-Axis, Wireless Target with 1" measuring range and .0001" resolution.
- Uses A-1520 Single-Axis Wireless Target with .250" range and 1 Micron (.00004") resolution for higher accuracy applications.
- Backlit split-prism levels accurate to 1 arc second.
- Instant on with virtually no warm-up.
- Typical setup time 20 minutes or less.
- Multiple mounting orientations.
- Battery or AC powered.
- Completely self-contained.
- Diode lasers 2 times more stable than HeNe based laser systems.
- Includes L-123 Pitch/Roll/Yaw base with coarse and fine adjustments.

How the Alignment System Works

To measure an injection-molding machine with the L-743, five reference points are needed. Three points are chosen on the fixed platen and one each on two tie bars, usually on the lower tie bars at a point closest to the platens. The laser is positioned beside or inside the machine on an instrument stand. One of the vertical laser planes is bucked in¹ to three reference points on the fixed platen. Next, the horizontal laser plane is bucked in to two tie bars by placing one target on each tie bar. To measure the machine's geometry, the targets that were zeroed to the reference points are used to measure the deviation of a measuring point from the reference point.

¹ **BUCK-IN**—Adjusting a laser plane or line to be parallel to the surface being measured (a table top, a surface plate, or a way surface). Three points are required to buck-in a laser plane to a reference surface. Two points are needed to buck-in a straight-line laser to a reference line (i.e., centerline).

Measuring Parallelism of Platens

To measure platen-to-platen parallelism, the laser plane is bucked in to the fixed platen. A target is then placed on the opposing or moveable platen and zeroed on one point, usually one corner. Next, the three other corners are measured for deviation from the first corner. The deviation, if any, is a measure of the parallelism of the platens. Since the laser measurement is live, the target can be left on the platen while it is being aligned. If all four corners read zero, then the two platens are parallel. The same method could also be used to check the parallelism of the molds to the platens.

Measuring Tie-Bar Squareness

Since the L-743 is comparable to three 100-foot (30.5 meter) long surface plates, each perpendicular to within 1 arc second (like a ceiling and two walls), measuring squareness of the tie bars of even the largest injection molding machines and presses is a simple task.

The process starts by setting up the laser to 5 points as described above. To measure the squareness, for example, of the two lower tie bars to the fixed platen in the vertical direction, a target would be zeroed at a point on each tie bar closest to the fixed platen. Since the vertical laser plane has been bucked in to the fixed platen, the horizontal plane is perpendicular to the fixed platen. After zeroing the target, it is traversed along the tie bar. A "+" reading indicates the tie bar is sloping "up hill" relative to the platen; a "-" reading means it is sloping "downhill". A bubble level on the target base keeps the target at top-dead center of the (round) tie bar.

To measure "horizontal" squareness of the same tie bar, the target can then be placed on the tie bar horizontally and zeroed to the 3rd (vertical) laser plane. As the target is moved along the tie bar horizontally (again a bubble level on the target base keeps the target at top-dead center), any deviation from the zero point is a measure of horizontal squareness of the tie bar.

The same method is used to measure the squareness of all four tie bars; however, it usually takes two setups to measure all the tie bars for squareness.

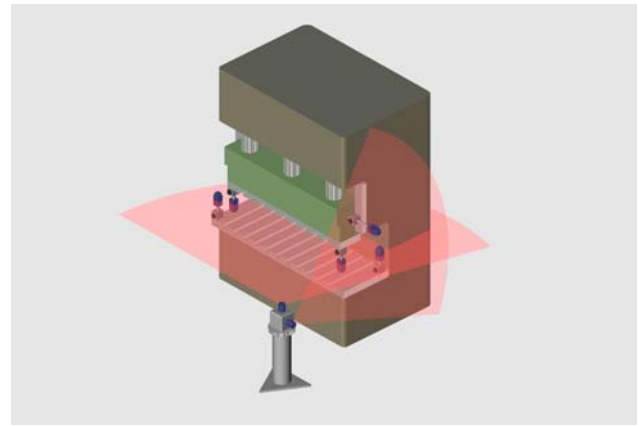

Recommended System Configuration

L-743 Ultra Precision Triple Scan Laser
A-1519 Single-Axis Wireless Target with 1" range and .0005" resolution
R-1309 Cassiopeia PDA Readout with Read9 Software and IR receiver
L-106 Instrument Stand
A-909 Shipping Case

Computer Accessories

R-342 Notebook Computer
R-1342 Toughbook Computer
A-908 IR Wireless Receiver
S-1388 Plane5 Software

Optional Accessories

A-1519HR Single-Axis Wireless Target with 1" range and .0001" resolution
A-1520 Single-Axis Wireless Target with .250" range and .00002" resolution for higher accuracy applications
A-1532 Universal Scan Target with 3" range and .001" resolution
A-1533 Universal Scan Target with swiveling head, 3" range and .001" resolution
A-1530 Digital Height Gage Target with pole

Alternative Systems

L-742 Ultra Precision Dual Scan Laser
For lower accuracy Injection Molding Machine Applications:
L-732 Precision Dual Scan Laser Alignment System

Injection Molding Machine Alignment

Side View (Without Removing Mold)

Please note that while this looks like a complex setup, it is the *machine* that makes the setup look difficult. The total time to set up the laser and reference it to the machine should be 13-25 minutes, including the time to take it out of the box. The total time to completely measure the machine for parallelism of the platens and squareness of the tie bars is 35-55 minutes (see timeline below).

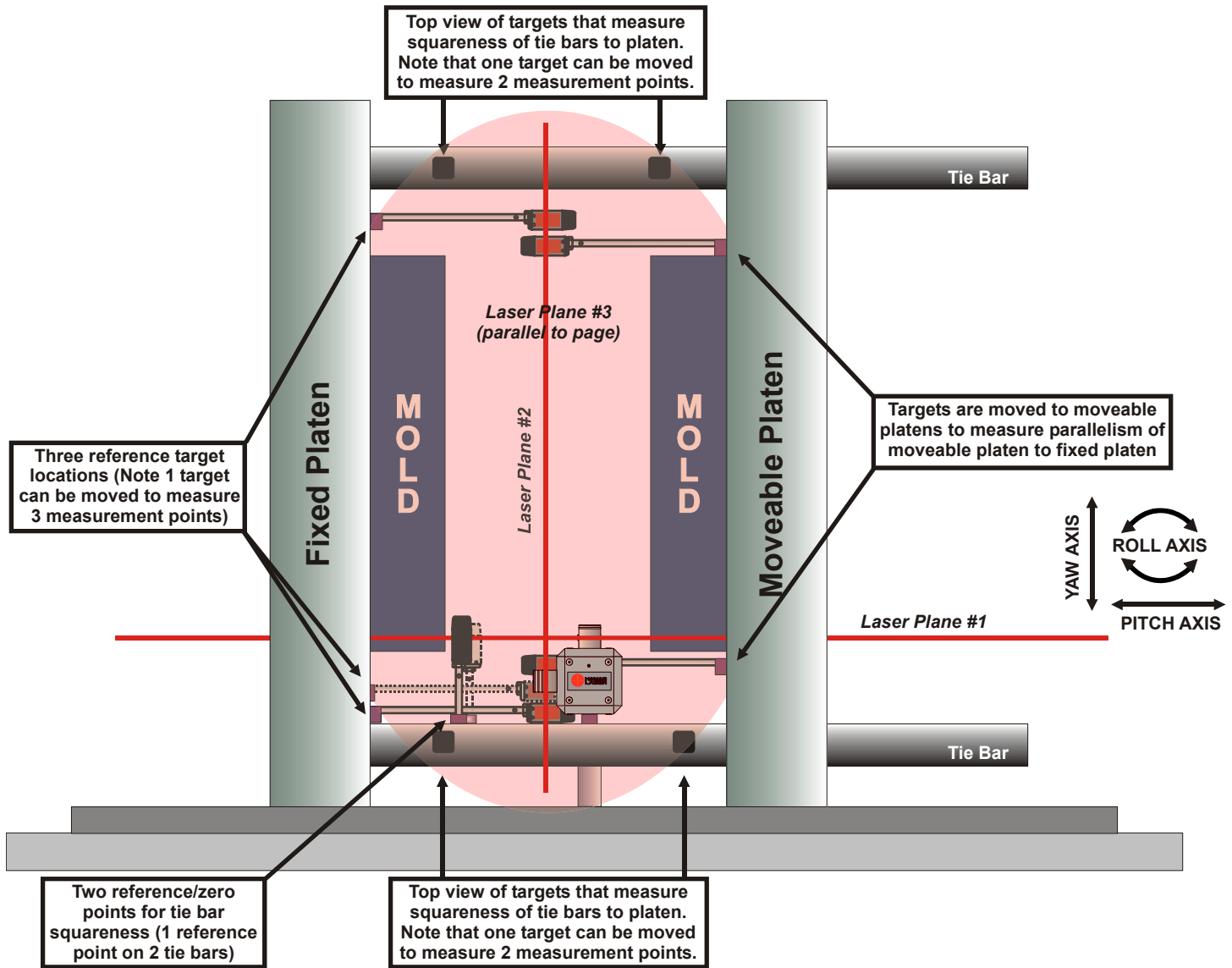

Top View

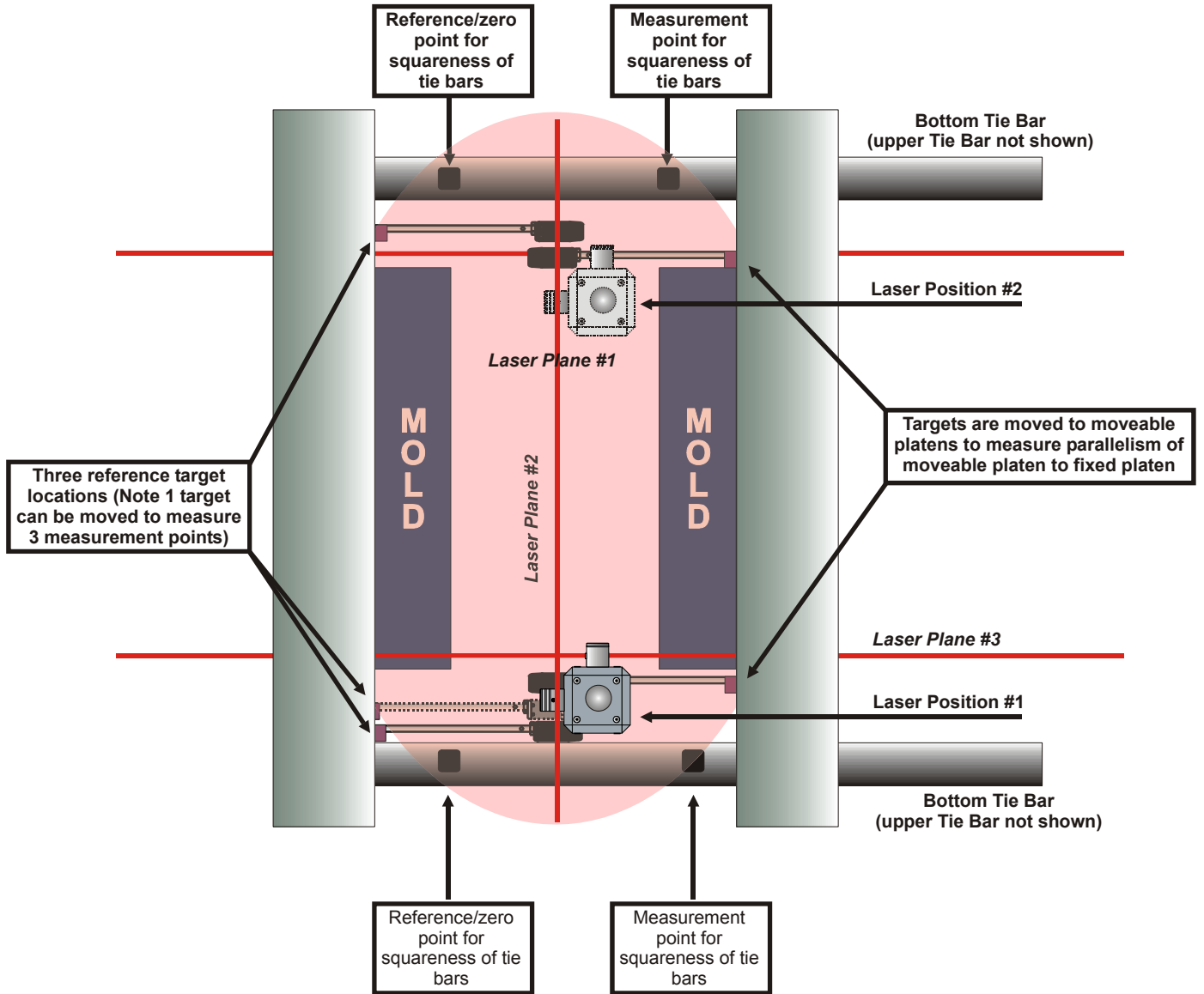

Front View of Platen

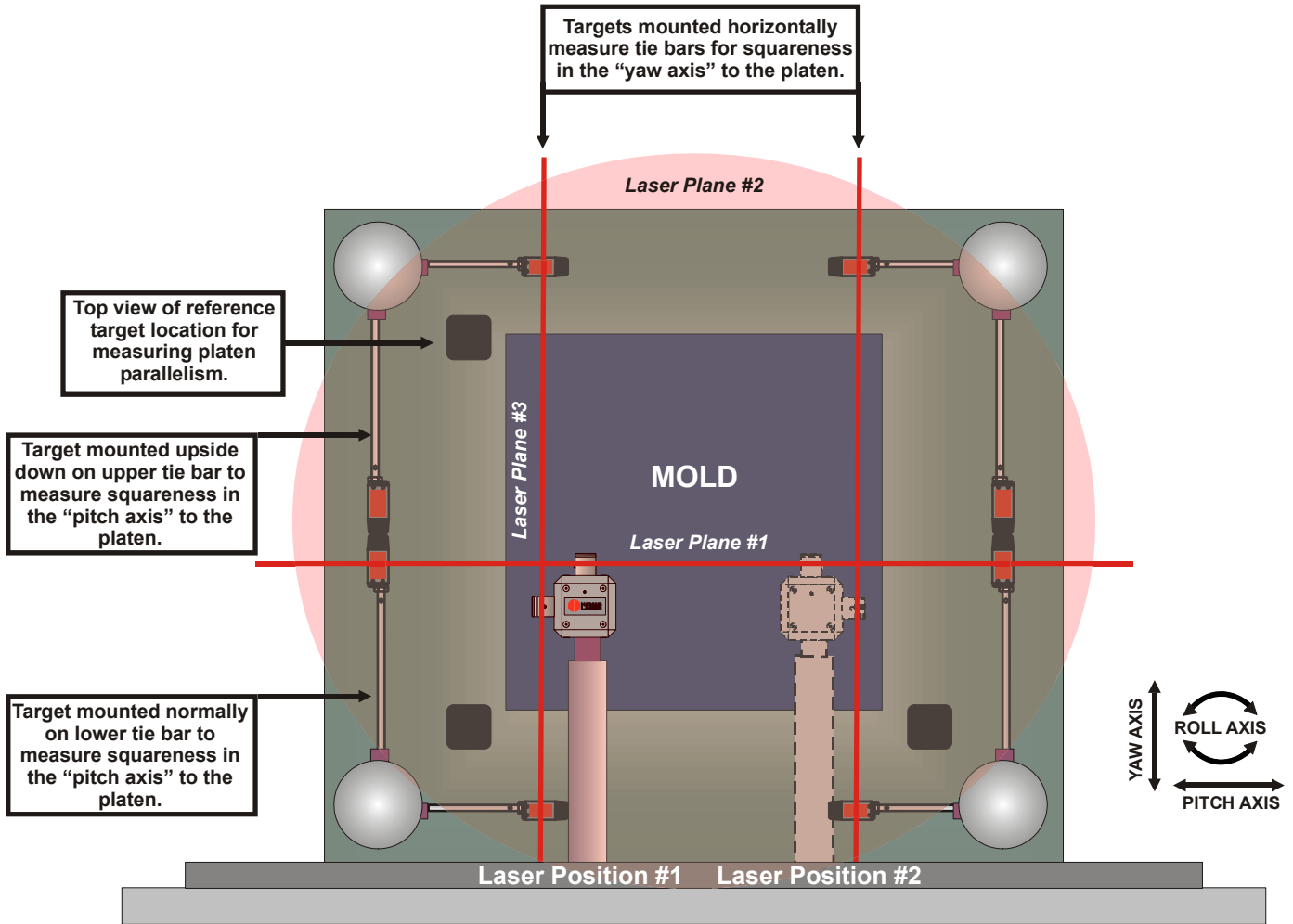

Procedure	Timeline (minutes)
1. Set the laser on an instrument stand either outside the machine or inside the machine as shown (Laser Position #1). Position the laser so the laser plane (LP) #1 is at a sufficient height to allow measurement of the upper tie bars for squareness. Ensure that there is sufficient room between the lower left tie bar and LP#3—75 mm to 300+ mm is the correct range.	5-10
2. Place a single-axis target (A-1519, A-1519HR or A-1533) in the lower left corner of the platen and zero. Mark the spot for reference purposes, and then move this target to the upper left side of the platen. Place a second target on the <i>same</i> point in the lower left corner of the platen and zero the display.	3-5
3. Adjust the pitch axis of the L-733/743 until the same reading appears on <i>both</i> targets. This means the laser is now parallel to these two points (shown on left side of the <i>Front View</i>). Re-zero both targets.	1-2
4. Move one of the two targets (without changing the zero point) to the lower right side of the platen. Adjust the yaw axis until the target at this location reads zero. Re-measure the other points to ensure that they all read zero. The laser plane is now parallel to the fixed platen.	
5. Mount a target on the lower left tie bar and level using the built-in level vial on the target base. This keeps the target at top dead center. Adjust the target height until it reads LP #1. Zero the target and mark the reference point. Move the target the lower right tie bar. Repeat this procedure with a second target, placing it on the same reference point on the lower left tie bar where the first target was zeroed.	3-6
6. Adjust LP#1 using the roll axis in the laser base until both targets read the same number, making the laser plane parallel to the two lower tie bars.	1-2
7. Now the laser is ready to measure parallelism and squareness of two of the four tie bars. <i>Note: Skip Steps 5 and 6 if tie-bar squareness is not desired.</i>	
8. To measure platen parallelism, assuming the moveable platen is within 1 meter of the fixed platen, place a target in one corner of the moveable platen. Add or remove rods from the targets so that the length of the target height allows it to read the laser plane. Zero the target (see <i>Side View</i>).	1-2
9. Move the target to the other three corners and note the readings. Any deviation from zero is a measurement of out-of-parallel condition of the moveable platen to the fixed platen. Since the readings are live, the target (or targets) can be left on the platen while it is being adjusted to bring it into alignment.	1
10. Since all three laser planes are perpendicular to each other, the laser is also now set up to start measuring tie-bar squareness. Note that the laser cannot measure all four tie bars for squareness with one setup (see Steps 16 and 17).	
11. To measure squareness of the lower tie bar to the platen in the pitch axis, (as defined by looking into the end of the tie bar) use the target that set up LP#1 (which should still be reading zero). Move the target the other end of the tie bar, where its reading will indicate the squareness. If it reads zero, then it's square to the platen. If not, then the amount shown on the readout is how much either the platen or the tie bar needs to move to bring it into specification. Again the reading is live, so the target can be left in place while the adjustments are being made.	1-2
12. Move the target along the tie bar in small increments to measure the tie bar for straightness. Note the readings as the target is moved.	
13. To measure the tie-bar squareness in the yaw axis (as defined by looking into the end of the tie bar), set up a target at the 3 o'clock position on the tie bar (see <i>Front View</i>). The level on the target base can be moved to the side of the base to keep it at top dead center.	1-3
14. Adjust the target until it picks up LP#3 and zero the target. As in Step 11, move the target to the other end of the tie bar to measure the squareness. If the reading not zero, it is not square. At the same time, the upper tie bar can be measured for squareness in the same yaw axis with the same setup.	1-3
15. The upper tie bar squareness in the pitch axis can be measured by turning the target up side down, picking up LP#1 and following Step 11. This also measures the parallelism of the upper tie bar to the lower tie bar in the pitch axis. Similarly, the upper and lower tie bars can be measured for parallelism in the yaw axis by using LP#3.	2-4
16. To measure the two right-hand tie bars, move the laser to Position #2 and repeat Steps 1-6 to make the laser planes parallel to the same reference.	5-10
17. Repeat Steps 11-15 to measure the squareness of the two right-hand tie bars.	3-5